

SIDE SECTION VIEW

RECOMMENDED ADA INSTALLATION

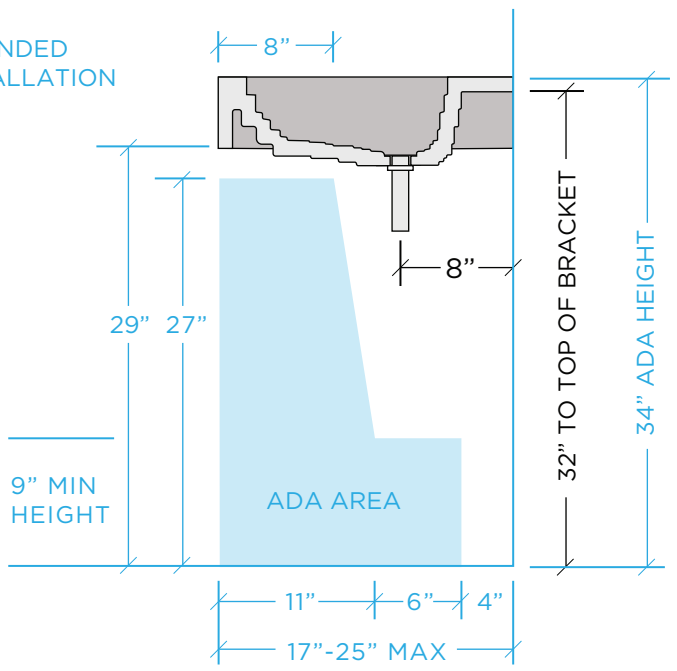

REAR ELEVATION

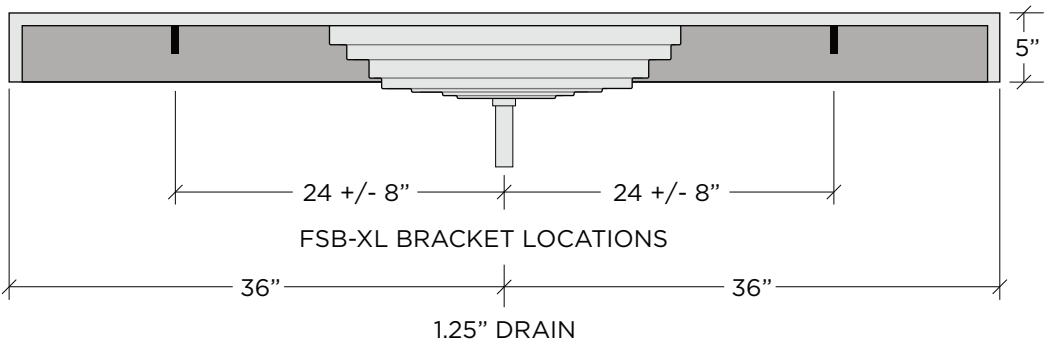

PLAN VIEW

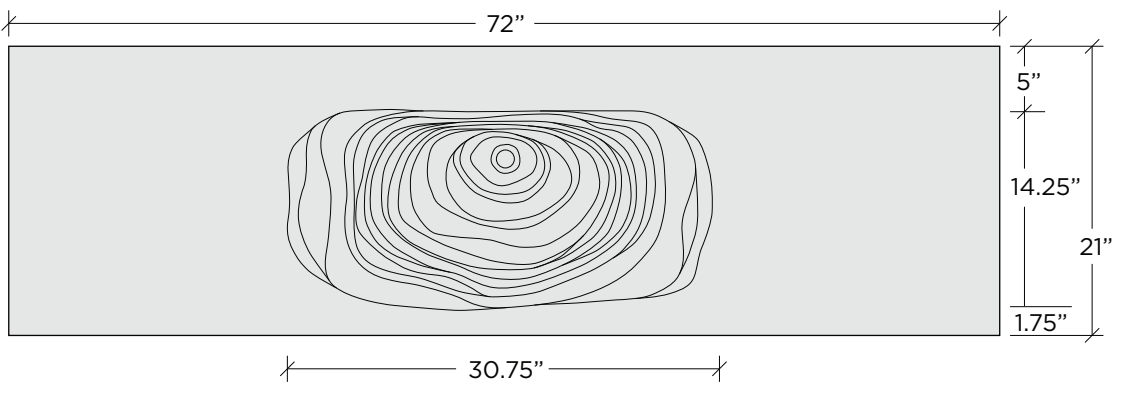

SPECIFICATIONS

- SINK BASIN ST-31-A DIMENSIONS = 30.75" x 14.25" x 5.5"
- OVERALL DIMENSIONS: 72" L x 21 D" x 5" H
- CONCRETE THICKNESS IS ~1" THROUGHOUT
- SINK HAS APRON HEIGHT OF 5"
- WEIGHT: ~150 LBS
- MOUNTS TO WALL WITH 2 SUPPORT BRACKETS (FSB-XL: QTY 2)



CSA B45.8/IAPMO Z403
ASME A112.18.2/CSA B125.2



ICC A117.1

STANDARD FAUCET HOLE CONFIGURATIONS (CUSTOMIZABLE):

- 1 SINGLE FAUCET HOLE OR TRIPLE HOLE SET CENTERED ABOVE BASIN
- TRIPLE HOLE SET = 8" SPREAD
- HOLE DIAMETER = 1 3/8"



STRATA SINK, 72"
SKU: FLO-STRATA-72-ADA

SCALE: N/A
PAGE 1 OF 1

ALL DESIGNS © TRUEFORM CONCRETE, LLC
ALL RIGHTS RESERVED. NOT FOR PUBLICATION

20.MAY.2025
DRAWN BY PG